

# M9203-AGx-2(Z) Series On/Off and Floating Point Electric Spring Return Actuators

## Installation Instructions

M9203-AGA-2, M9203-AGB-2,  
M9203-AGA-2Z, M9203-AGB-2Z

Part No. 34-1791-8, Rev. —  
Issued February 16, 2011

Refer to the [QuickLIT Web site](#) for the most up-to-date version of this document.

### Applications

The M9203-AGx-2(Z) Series On/Off and Floating Point Electric Spring Return Actuators are direct-mount actuators that operate on AC/DC 24 V power. These bidirectional actuators do not require a damper linkage, and are easily installed on round shafts from 1/4 to 1/2 in. (6 to 12 mm) or square shafts from 1/4 to 5/16 in. (6 to 8 mm) using the standard shaft clamp included with the actuator.

A single M9203-AGx-2(Z) Series On/Off and Floating Point Electric Spring Return Actuator provides 27 lb-in. (3 N·m) running and spring return torque. An integral line voltage auxiliary switch, available only on the M9203-xxB-2(Z) models, indicates end-stop position, or performs switching functions within the selected rotation range.

M9203-AGA-2(Z) actuators include plenum-rated cables and are specially configured for installation in spaces used for environmental air-handling purposes other than ducts and plenums as specified in National Fire Protection Association (NFPA) 70: National Electrical Code section 300.22(C), Other Space Used for Environmental Air. The space over a hung ceiling used for environmental air handling purposes is an example of the type of space for which these actuators are configured.

**IMPORTANT:** Use this M9203-AGx-2(Z) Series On/Off and Floating Point Electric Spring Return Actuator only to control equipment under normal operating conditions. Where failure or malfunction of the electric actuator could lead to personal injury or property damage to the controlled equipment or other property, additional precautions must be designed into the control system. Incorporate and maintain other devices, such as supervisory or alarm systems or safety or limit controls, intended to warn of or protect against failure or malfunction of the electric actuator.

### Installation

The M9203-AGx-2(Z) Series On/Off and Floating Point Electric Spring Return Actuators mount directly to the surface in any convenient orientation using two No. M3.5 x 9.5 mm self-drilling sheet metal screws and the anti-rotation bracket (parts included with the actuator). No additional linkages or couplers are required. Electrical connections are color-coded and identified with numbers permanently marked on the actuator cable. A tag on the actuator cable identifies the electrical connections and wiring details are included on the actuator housing.

**IMPORTANT:** Before specifying M9203-AGx-2(Z) Series On/Off and Floating Point Electric Spring Return Actuators for plenum applications, verify acceptance of exposed plastic materials in plenum areas with the local building authority. Building codes for plenum requirements vary by location. Some local building authorities accept compliance to UL 1995, Heating and Cooling Equipment, while others use different acceptance criteria.

**IMPORTANT:** Do not install or use this M9203-AGx-2(Z) Series On/Off and Floating Point Electric Spring Return Actuator in or near environments where corrosive substances or vapors could be present. Exposure of the electric actuator to corrosive environments may damage the internal components of the device, and will void the warranty.

### Parts Included

- M9203-AGx-2(Z) actuator
- M9203-603 adjustable stop kit
- M9000-604 anti-rotation bracket with two No. M3.5 x 9.5 mm, pan-head, cross-recessed (Phillips), self-drilling and self-tapping screws

### Special Tools Needed

- 10 mm wrench/socket
- drill with Phillips bit, driver size 1

## Dimensions

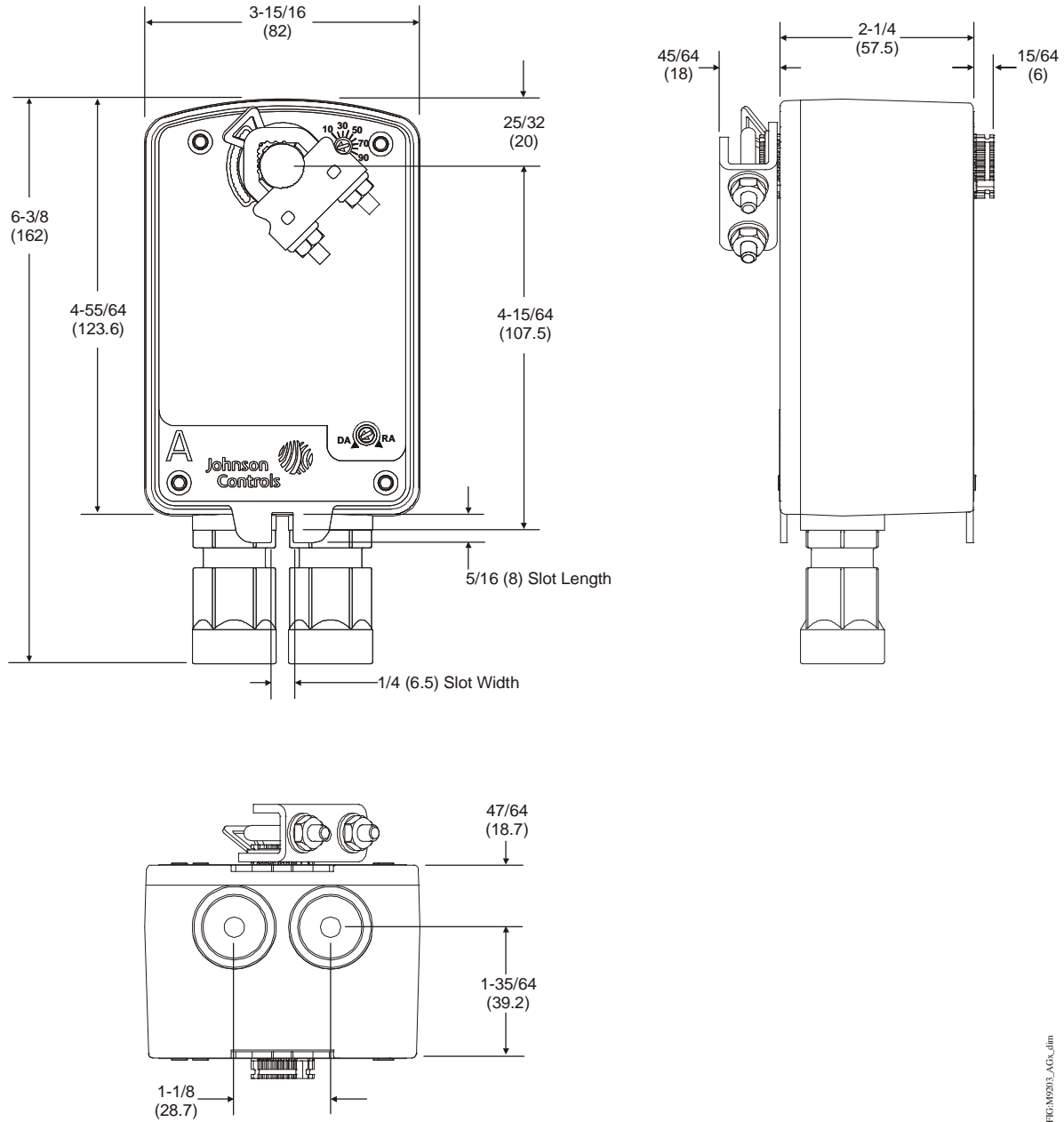

FIG:M9203-AGx\_dim

**Figure 1: M9203-AGx-2 Series On/Off and Floating Point Electric Spring Return Actuator Dimensions, in. (mm)**

## Accessories

**Table 1: Accessories and Replacement Parts (Order Separately)**

Code Number	Description
<b>DMPR-KC003<sup>1</sup></b>	7 in. (178 mm) Blade Pin Extension (without bracket) for Johnson Controls® Direct-Mount Damper Applications (quantity 1)
<b>M9000-200</b>	Commissioning Tool that provides a control signal to drive 24 V On/Off, Floating, Proportional, and/or Resistive Electric Actuators (quantity 1)
<b>M9000-321</b>	Weathershield Kit for Damper Application of M9203 and M9208 Series Electric Spring Return Actuators (quantity 1)
<b>M9000-341</b>	Weathershield Kit for VG1000 Series Ball Valve application of M(VA)9104, M(VA)9203, and M(VA)9208 Series Electric Spring Return Actuators (quantity 1)
<b>M9000-400</b>	Jackshaft Linkage Adapter Kit (quantity 1)
<b>M9000-560</b>	Ball Valve Linkage Kit for applying M9104, M9203, and M9208 Series Electric Actuators to VG1000 Series Valves (quantity 1)
<b>M9000-561</b>	Thermal Barrier Kit for M9000-560 Ball Valve Linkage. Extends M(VA)9104, M(VA)9203, and M(VA)9208 Series Electric Spring Return Actuators applications to include low pressure steam (quantity 1)
<b>M9000-604</b>	Replacement Anti-Rotation Bracket Kit for M9203, M9208, M9210, and M9220 Series Electric Spring Return Actuators (quantity 1)
<b>M9000-606</b>	Position Indicator for Damper Applications (quantity 5)
<b>M9000-607</b>	Position Indicator for VG1000 Series Ball Valve Applications (quantity 5)
<b>M9203-100</b>	Remote Mounting Kit with Crankarm Kit (quantity 1)
<b>M9203-110</b>	Universal Mounting Kit without Crankarm Kit (quantity 1)
<b>M9203-115</b>	Universal Mounting Kit with Crankarm Kit (quantity 1)
<b>M9203-150</b>	Crankarm Kit (quantity 1)
<b>M9203-250</b>	Remote Mounting Kit with Crankarm Kit and Damper Linkage for D1300 Dampers (quantity 1)
<b>M9203-601</b>	Replacement Standard Coupler Kit (with Retainer) for Mounting M9203 Series Electric Spring Return Actuators (quantity 1)
<b>M9203-602</b>	Replacement Retainer for M9203 Series Electric Spring Return Actuators (quantity 5)
<b>M9203-603</b>	Adjustable Stop Kit for M9203 Series Electric Spring Return Actuators (quantity 1)

1. Furnished with the damper and may be ordered separately.

## Mounting

The M9203-AGx-2(Z) Series On/Off and Floating Point Electric Spring Return Actuators can be easily installed on dampers with round shafts from 1/4 to 1/2 in. (6 to 12 mm) or square shafts from 1/4 to 5/16 in. (6 to 8 mm) using the standard shaft coupler included with the actuator. If the damper shaft extends less than 3.31 in. (84 mm), see the Removable Coupler section for further instructions. If the damper shaft extends less than 0.79 in. (20 mm), install a shaft extension recommended by the damper manufacturer.

**Counterclockwise (CCW) Spring Return  
Direction – Clockwise (CW) Powered  
Operation**

For CCW spring return direction, mount the actuator to the damper shaft so that Side A of the actuator is away from the damper as illustrated in Figure 2. With power applied, the actuator drives CW from the 0° position and spring returns CCW.

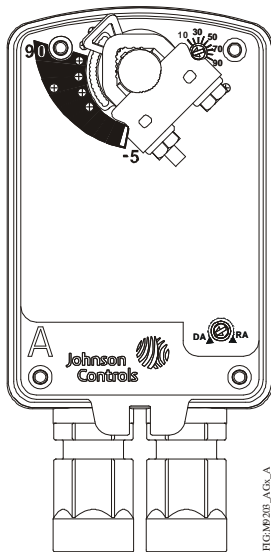

**Figure 2: Actuator Side A**

**Clockwise (CW) Spring Return Direction –  
Counterclockwise (CCW) Powered Operation**

For CW spring return direction, mount the actuator to the damper shaft so that Side B of the actuator is away from the damper as illustrated in Figure 3. With power applied, the actuator drives CCW from the 0° position and spring returns CW.

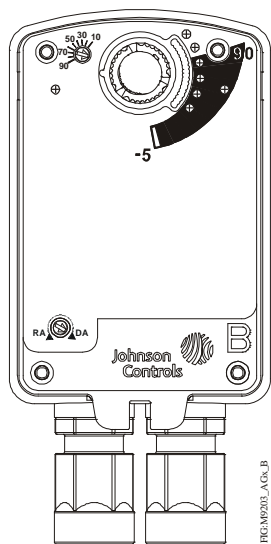
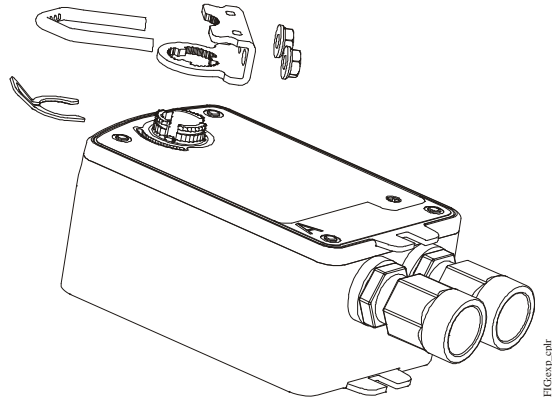

**Figure 3: Actuator Side B**

**Removable Coupler**

If the damper shaft extends less than 3.31 in. (84 mm), mount the coupler on the face of the actuator closest to the damper.

If the damper shaft extends less than 0.79 in. (20 mm), a shaft extension is required to mount the actuator.



**Figure 4: Changing the Coupler Position**

To change the coupler's position, see Figure 4 and proceed as follows:

1. Mount the coupler on either Side A or Side B of the actuator as determined by the shaft length.
2. Snap the locking clip securely into the coupler retention groove to retain the coupler.

**Mounting the Actuator**

To mount the actuator, proceed as follows:

1. See the dimensions in Figure 5 and Table 2 to ensure the correct positioning of the anti-rotation bracket.

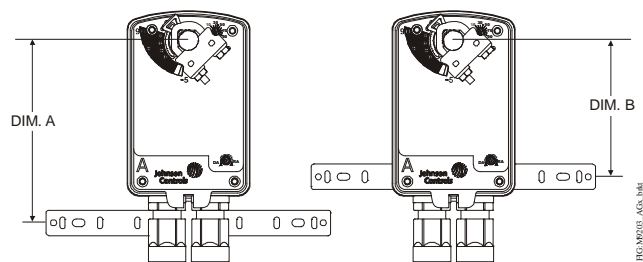
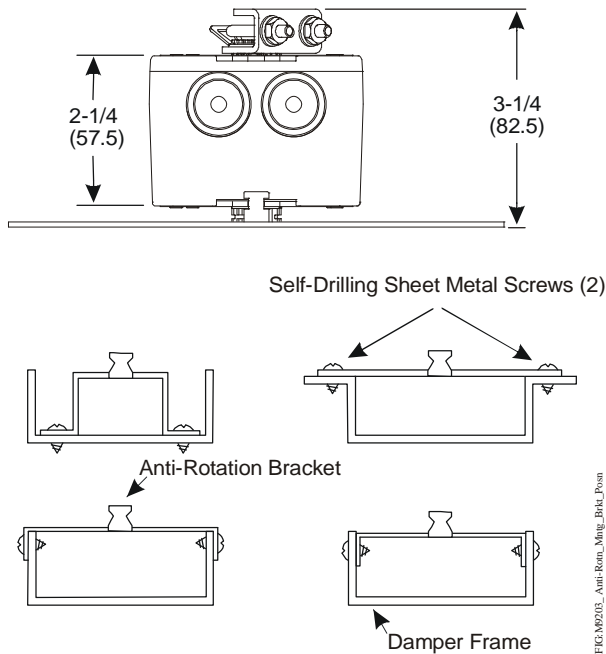

**Figure 5: Positioning the Anti-Rotation Bracket**

**Table 2: Dimensions from Anti-Rotation Bracket to Shaft Center**

Shaft Diameter, in. (mm)	Dimension A, in. (mm)	Dimension B, in. (mm)
1/4 to 1/2 (6 to 12)	4-27/32 (123)	3-5/8 (92)

**IMPORTANT:** The tab on the anti-rotation bracket must fit midpoint in the actuator slot. Positioning the tab midpoint in the slot prevents actuator binding and premature wear, and makes actuator removal easier.



**Figure 6: Anti-Rotation Mounting Bracket Positions**

2. Bend or cut the anti-rotation bracket to fit the damper frame or duct as illustrated in Figure 6.  
**Note:** The anti-rotation bracket can be bent to fit a round damper.
3. Mark or drill mounting holes in the damper frame or duct using the anti-rotation bracket as a guide (based on the measurements obtained in Table 2 and Figure 5).
4. Secure the anti-rotation bracket to the damper frame or duct using the two No. M3.5 x 9.5 mm self-drilling sheet metal screws provided.

**IMPORTANT:** Do not overtighten the mounting screws to avoid stripping the threads. Be certain that the tab on the anti-rotation bracket remains properly positioned in the slot on the actuator, and that the actuator remains parallel to the mounting surface.

5. Slide the actuator onto the damper shaft, and position the anti-rotation bracket tab into the slot at the bottom of the actuator as illustrated in Figure 6.
6. Rotate the damper blade(s) to the desired position if the power is lost.

7. Hold the actuator perpendicular to the damper shaft. Evenly hand-tighten each nut on the coupler U-bolt, then torque the coupler U-bolt nuts to 100 to 125 lb-in. (11 to 14 N·m).
8. Apply power long enough for the actuator to travel a full stroke. Verify that the actuator rotates freely throughout the range.

### Limiting Rotation Range Using M9203-603 Adjustable Stop Kit

The actuator is factory set for 95° rotation, and its range is limited in 5° increments to a minimum of 35°. A stroke-limiting stop can be attached in the field to the shaft coupler side of the actuator to reduce the rotation range. Attaching the stroke-limiting stop in the furthest mounting position reduces the rotation range of the actuator by 5°. Each progressive mounting position reduces the rotation range an additional 5°.

1. Check that the damper blade is visible or its position is permanently marked on the end of the damper shaft, as illustrated in Figure 7.

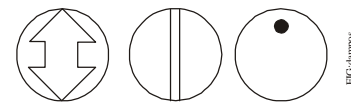

**Figure 7: Damper Position Icons**

2. Position the stroke-limiting stop in the serrated slot with its leading edge at the scale position matching the desired stroke.
3. The product label marks hole positions for the M3-0.5 x 8 mm self-tapping screw provided with the adjustable stop kit. Drive the screw through the slot in the adjustable stop and into the actuator face over a marked hole position. (See Figure 8.)

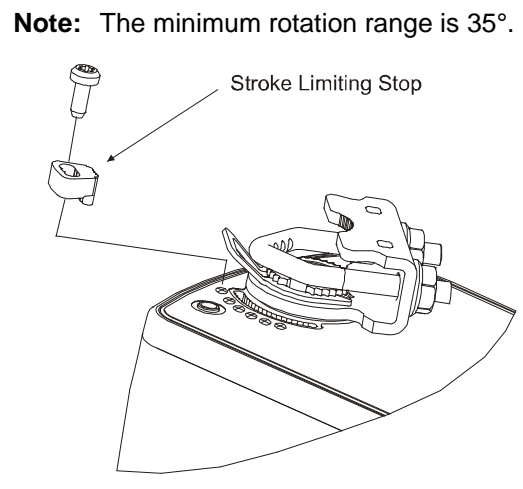

**Figure 8: Limiting Rotation Range**

## Wiring

See Figure 9 and Figure 10 to wire the applicable M9203-AGx-2(Z) Series model.

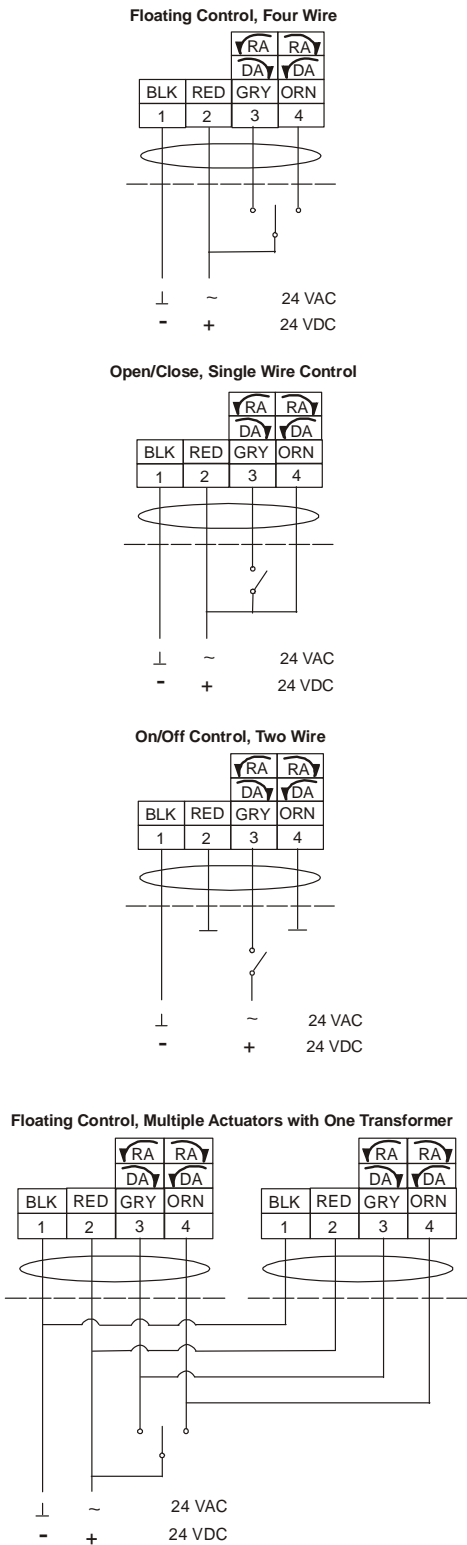

Figure 9: Control Wiring Diagrams

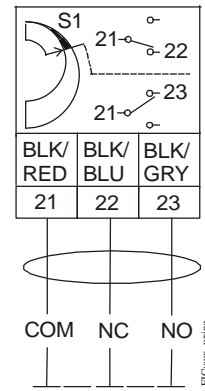

Figure 10: Auxiliary Switch Wiring Diagram



**WARNING: Risk of Electric Shock.**

Disconnect or isolate all power supplies before making electrical connections. More than one disconnect or isolation may be required to completely de-energize equipment. Contact with components carrying hazardous voltage can cause electric shock and may result in severe personal injury or death.



**CAUTION: Risk of Property Damage.**

Do not apply power to the system before checking all wiring connections. Short circuited or improperly connected wires may result in permanent damage to the equipment.



**CAUTION: Risk of Property Damage.**

Insulate and secure each unused wire lead before applying power to the actuator. Failure to insulate and secure each unused wire lead may result in property damage.

**IMPORTANT:** Make all wiring connections in accordance with the National Electrical Code and local regulations. Use proper Electrostatic Discharge (ESD) precautions during installation and servicing to avoid damaging the actuator's electronic circuits.

## Using Conduit

All M9203-xxx-2(Z) Series Actuators accept 1/2 in. threaded electrician's fittings.

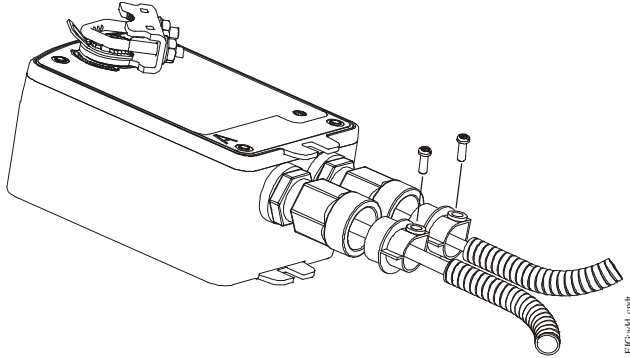

**Figure 11: Adding Flexible Metal Conduit**

1. Feed the actuator cables through the field supplied electrician's fitting and conduit.
2. Thread the electrician's fitting into the actuator and secure the conduit to the fitting in accordance with local building code requirements.

## Setup and Adjustments

### Mode Selection Switch

Actuators have an external mode selection switch to reverse control logic. The switch is accessible from both A and B sides of the actuator as illustrated in Figure 12. Actuators are delivered in Direct Acting (DA) mode and can be switched by the user to Reverse Acting (RA) mode.

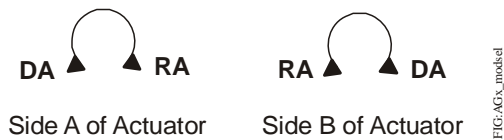

**Figure 12: Mode Selection**

## Control Response

The installation side of the actuator and the position of the mode selection switch combine to determine control response from the actuator. See Figure 13.

Control Inputs		Mode Selection Switch			
GRY	ORN	A		B	
3	4	DA	RA	RA	DA
CLOSED	OPEN	↘	↙	↘	↙
OPEN	CLOSED	↙	↘	↙	↘
OPEN	OPEN	STOP	STOP	STOP	STOP
CLOSED	CLOSED	↘	↙	↘	↙

**Figure 13: Control Response**

### Auxiliary Switch (M9203-xxB-2(Z) Models)

The M9203-xxB-2(Z) models include one integral auxiliary switch with a switch adjuster accessible on either face of the actuator (see Figure 2 and Figure 3). The factory setting for the Auxiliary Switch is 11° closing (relative to the 0 to 90° rotation range as printed on the product label). See the [Technical Specifications](#) table for the auxiliary switch ratings.



#### **WARNING: Risk of Electric Shock and Property Damage.**

Insulate and secure each unused wire lead before applying power to the actuator. Failure to insulate and secure each unused wire lead may result in property damage, electric shock, and severe personal injury or death.

The switch point is continuously adjustable throughout the actuator's rotation range. For the most accurate switch positioning, see Figure 14 and use the method in the following example.

To change the switch point, proceed as follows:

1. Position the actuator in the full spring return position.

**Note:** The switch is factory set to trip when the actuator reaches the 11° position.

2. Rotate the switch adjuster until it points to the desired switch point.

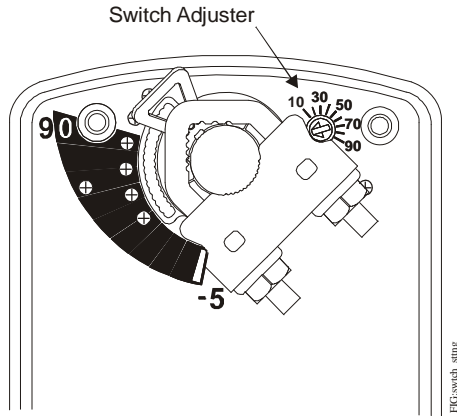

**Figure 14: Switch Trip Point Settings**

3. Connect the Auxiliary Switch to a power source or an ohmmeter and apply power to the actuator. The actuator moves to the fully open position and holds while power is applied.
4. Observe the switch point. If required, repeat Step 1 through Step 3.

### **Repair Information**

A number of replacement parts are available; see Table 1 for more details. If an M9203-AGx-2(Z) Series On/Off and Floating Point Control Electric Spring Return Actuator fails to operate within its specifications, replace the unit. For a replacement electric actuator, contact the nearest Johnson Controls representative.



## Technical Specifications

### M9203-AGx-2(Z) Series On/Off and Floating Point Control Electric Spring Return Actuator (Part 1 of 2)

<b>Power Requirements</b>	<b>-AGx-2 Models</b>	AC 24 V (AC 19.2 V to 28.8 V) at 50/60 Hz: Class 2 (North America) or Safety Extra-Low Voltage (SELV) (Europe), 4.7 VA Running, 2.7 VA Holding Position DC 24 V (DC 21.6 V to 28.8 V): Class 2 (North America) or SELV (Europe), 1.8 W Running, 1 W Holding Position Minimum Transformer Size: 6 VA per Actuator
	<b>-AGx-2Z Models</b>	AC 24 V (AC 19.2 V to 28.8 V) at 50/60 Hz: Class 2 (North America) or Safety Extra-Low Voltage (SELV) (Europe), 5.1 VA Running, 2.8 VA Holding Position DC 24 V (DC 19.2 V to 28.8 V): Class 2 (North America) or SELV (Europe), 1.9 W Running, 1.1 W Holding Position Minimum Transformer Size: 6 VA per Actuator
<b>Input Signal</b>	<b>-AGx-2(Z) Models</b>	AC 19.2 to 28.8 V at 50/60 Hz or DC 24 V +20%/-10% Class 2 (North America) or SELV (Europe) Minimum Pulse Width: 500 msec
<b>Control Input Impedance</b>	<b>-AGx-2(Z) Models</b>	4,700 ohm
<b>Auxiliary Switch Rating</b>	<b>-xxB Models</b>	One Single-Pole, Double-Throw (SPDT), Double-Insulated Switch with Silver Contacts: AC 24 V, 50 VA Pilot Duty AC 120 V, 5.8 A Resistive, 1/4 hp, 275 VA Pilot Duty AC 240 V, 5.0 A Resistive, 1/4 hp, 275 VA Pilot Duty
<b>Spring Return</b>		Direction Is Selectable with Mounting Position of Actuator: Actuator Face Labeled A Is Away from Damper or Valve: CCW Spring Return Actuator Face Labeled B Is Away from Damper or Valve: CW Spring Return
<b>Rated Torque</b>	<b>Power On (Running)</b>	27 lb-in. (3 N-m) All Operating Temperatures
	<b>Power Off (Spring Returning)</b>	27 lb-in. (3 N-m) All Operating Temperatures
<b>Rotation Range</b>		Maximum Full Stroke: 95° Adjustable Stop: 35 to 95° Maximum Position
<b>Rotation Time for 90 Degrees of Travel</b>	<b>Power On (Running) -AGx-2 Models</b>	150 Seconds Constant for 0 to 27 lb-in. (3 N-m) Load, at All Operating Conditions
	<b>Power On (Running) -AGx-2Z Models</b>	90 Seconds Constant for 0 to 27 lb-in. (3 N-m) Load, at All Operating Conditions
	<b>Power Off (Spring Returning)</b>	12 to 17 Seconds for 0 to 27 lb-in. (3 N-m) Load, at Room Temperature 16 Seconds Nominal at Full Rated Load 22 Seconds Maximum with 27 lb-in. (3 N-m) Load at -22°F (-30°C)
<b>Life Cycles</b>		60,000 Full Stroke Cycles with 27 lb-in. (3 N-m) Load 1,500,000 Repositions with 27 lb-in. (3 N-m) Load

**M9203-AGx-2(Z) Series On/Off and Floating Point Control Electric Spring Return Actuator  
(Part 2 of 2)**

<b>Audible Noise Rating</b>	<b>Power On (Running) -AGx-2 Models</b>	<28 dBA at 27 lb-in. (3 N·m) Load, at a Distance of 39-13/32 in. (1 m)
	<b>Power On (Running) -AGx-2Z Models</b>	<37 dBA at 27 lb-in. (3 N·m) Load, at a Distance of 39-13/32 in. (1 m)
	<b>Power On (Holding)</b>	<20 dBA at a Distance of 39-13/32 in. (1 m)
	<b>Power Off (Spring Returning)</b>	<56 dBA at 27 lb-in. (3 N·m) Load, at a Distance of 39-13/32 in. (1 m)
<b>Electrical Connections</b>	<b>-AGA-2(Z) Models</b>	120 in. (3.05 m) UL 444 Type CMP Plenum Rated Cable with 19 AWG (0.75 mm <sup>2</sup> ) Conductors and 0.25 in. (6 mm) Ferrule Ends
	<b>Auxiliary Switch (-xxB Models)</b>	48 in. (1.2 m) UL 758 Type AWM Halogen Free Cable with 18 AWG (0.85 mm <sup>2</sup> ) Conductors and 0.25 in. (6 mm) Ferrule Ends
<b>Conduit Connections</b>		Integral 1/2 in. (13 mm) Threaded Conduit Connector(s)
<b>Mechanical Connections</b>	<b>Round Shafts</b>	Range of Sizes: 1/4 to 1/2 in. (6 to 12 mm)
	<b>Square Shafts</b>	Range of Sizes: 1/4 to 5/16 in. (6 to 8 mm)
<b>Enclosure Rating</b>		NEMA 2 (IP54) for all Mounting Orientations
<b>Ambient Conditions</b>	<b>Standard Operating</b>	-22 to 140°F (-30 to 60°C); 90% RH Maximum, Noncondensing
	<b>Storage</b>	-40 to 185°F (-40 to 85°C); 95% RH Maximum, Noncondensing
<b>Dimensions</b>		6.38 x 3.23 x 2.26 in. (162 x 82 x 57.5 mm)
<b>Compliance</b>  	<b>United States</b>	UL Listed, CCN XAPX, File E27734; to UL 60730-1A: 2003-08, Ed. 3.1, Automatic Electrical Controls for Household and Similar Use; and UL 60730-2-14: 2002-02, Ed. 1, Part 2, Particular Requirements for Electric Actuators. (Models: All)
	<b>Canada</b>	UL Listed, CCN XAPX7, File E27734; to UL 60730-1:02-CAN/CSA: July 2002, 3rd Ed., Automatic Electrical Controls for Household and Similar Use; and CSA C22.2 No. 24-93 Temperature Indicating and Regulating Equipment (Models: All)
	<b>Europe</b>	CE Mark – Johnson Controls, Inc., declares that this product is in compliance with the essential requirements and other relevant provisions of the EMC Directive 2004/108/EC and Low Voltage Directive 2006/95/EC.
	<b>Australia and New Zealand</b>	C-Tick Mark, Australia/NZ Emissions Compliant (Models: All)
<b>Shipping Weight</b>		-AGA Models: 2.0 lb (0.9 kg) -AGB Models: 2.4 lb (1.1 kg)



**Building Efficiency**

507 E. Michigan Street, Milwaukee, WI 53202

*Metasys® and Johnson Controls® are registered trademarks of Johnson Controls, Inc.  
All other marks herein are the marks of their respective owners. © 2011 Johnson Controls, Inc.*